

STREET WORKOUT WO-2703 Slackline

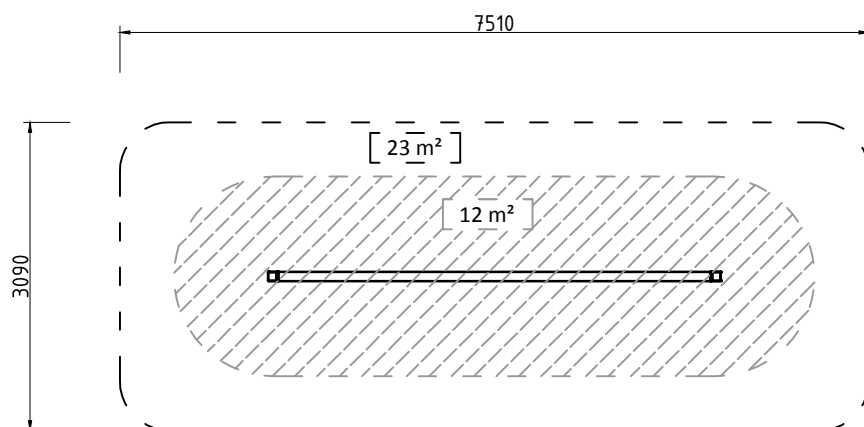
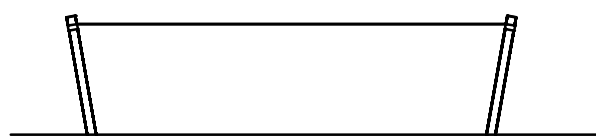
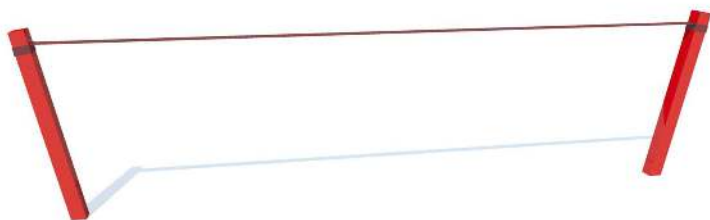

General information on street workout:

Product type: Fitness, stretching, exercise & workout.

Application: Workout is a permanently installed and freely accessible fitness equipment intended for sporting activities and exercising to improve physical and mental skills and abilities of users. Users may use the equipment with or without supervision and help of others.

Users: In accordance with the applicable DIN EN 16630:2015, workout systems may be used by people with a minimum height of 140 cm and maximum weight of 120 kg. Other than intended use is strictly prohibited.

Safety instructions: While using the workout system, follow the instructions shown in the information boards on the equipment. Exercise slowly and in a controlled way. Physical issues may occur in case of excessive load. In case of any doubts, consult the training or individual exercises with your physician to make sure there are no obstructions preventing from safe use of the workout system. Avoid overload of individual parts of the system and do not use the system if the surface is covered by frost, slippery, hot or the equipment is visibly damaged.

Product number	WO-2703
Maximum load	120 kg/person
System area	4510 x 90 x 1200
Movement area	7510 x 3090
Free fall height	max. 1100
System instalation	3 persons, 2 hours
Type of anchorage	Pursuant to installation manual.

All values are stated in millimeters

